

 **ModSecur<sup>®</sup> UPS**  
*Uninterruptible Power Supply*



USER MANUAL

**MODSECUR MT60-200**

## **SAVE THIS MANUAL**

This manual contains important instructions and warnings that you should follow during the installation, operation, storage and maintenance of this product. Failure to heed these instructions and warnings will void the warranty.

Copyright © 2022 by Maxiglobal. All Rights Reserved. All rights of this User Manual (“Manual”), including but not limited to the contents, information, and figures are solely owned and reserved by Maxiglobal. The Manual can only be applied to the operation or the use of this product. Any disposition, duplication, dissemination, reproduction, modification, translation, extraction, or usage of this Manual in whole or in part is prohibited without the prior written permission of Maxiglobal. Given that Maxiglobal will continuously improve and develop the product, changes may be made to the information in this Manual at any time without obligation to notify any person of such revision or changes. Maxiglobal will make all possible efforts to secure the accuracy and the integrity of this Manual. Maxiglobal disclaims any kinds or forms of warranty, guarantee, or undertaking, either expressly or implicitly, including but not limited to the completeness, faultlessness, accuracy, non-infringement, merchantability or fitness for a particular purpose of the Manual.

## Table of contents

1. Precautions.....	1
2. Installation procedure.....	3
2.1. Introduction.....	3
2.2. Preliminary checks.....	3
2.3. Location.....	4
2.3.1. UPS room.....	4
2.3.2. Battery room.....	4
2.3.3. Storage.....	4
2.4. Unpacking, checking and setting.....	4
2.4.1. Unpacking.....	5
2.4.2. Design and dimensions of the UPS.....	6
2.4.3. Service space.....	7
2.5. Safety elements.....	8
2.5.1. UPS input power supply.....	8
2.5.2. Battery circuit protection.....	9
2.6. Power cords.....	9
2.6.1. Maximum currents of the power supply.....	11
2.6.2. Connecting wires.....	11
2.7. Communication.....	14
2.7.1. Extended communication card Dry Contact.....	15
2.7.2. Control module.....	15
2.7.3. SNMP card.....	15
2.7.4. Monitoring card.....	15
3. UPS operation modes.....	17
3.1. Introduction.....	17
3.2. Principle of operation.....	17
3.2.1. Bypass module.....	18
3.3. Power supply operation modes.....	18
3.3.1. Online mode.....	18
3.3.2. Battery mode.....	19
3.3.3. The restart mode of the power supply after power back.....	19
3.3.4. Bypass mode.....	19
3.3.5. Service bypass.....	19
3.3.6. ECO mode.....	19
3.3.7. Frequency converter mode.....	20
3.3.8. Parallel mode.....	20
4. User manual.....	20
4.1. Power connectors.....	20

- 4.2. Procedures for starting the power supply - single operation.....22
  - 4.2.1. Starting the UPS from complete shutdown.....22
  - 4.2.2. Starting UPS with the battery pack.....23
- 4.3. Procedures for switching the power supply between operating modes.....23
  - 4.3.1. Switching from normal operation to battery operation.....23
  - 4.3.2. Switching from normal operation to Bypass operation.....23
  - 4.3.3. Switching from Bypass mode to normal operation.....23
  - 4.3.4. Switching from normal operation to service Bypass mode.....24
  - 4.3.5. Switching from service Bypass mode to normal operation.....24
- 4.4. The procedure of complete switching off the power supply (power supply by mechanical bypass).....25
- 4.5. Emergency shutdown using EPO.....25
- 5. LCD panel operation.....25
  - 5.1. Introduction.....25
  - 5.2. Indication of UPS operation status on the display.....26
  - 5.3. Reading work parameters.....30
    - 5.3.1. Power supply to bypass track.....30
    - 5.3.2. Power supply to the rectifier's track.....30
    - 5.3.3. Battery.....31
    - 5.3.4. UPS output.....31
  - 5.4. Reading information about UPS (Event log).....32
    - 5.4.1. Event Log.....32
    - 5.4.2. User Log.....33
    - 5.4.3. Information about the device.....33
  - 5.5. System configuration settings.....34
    - 5.5.1. Power parameters.....35
    - 5.5.2. Battery settings.....35
    - 5.5.3. Battery tests.....36
  - 5.6. Special functions.....37
  - 5.7. Display settings.....37
  - 5.8. Password settings.....37
  - 5.9. System speaker.....38
  - 5.10. Turn On/Off.....38

## 1. Precautions

This user's guide contains the necessary information on the installation and use of MT 60-200 power supplies. Before installing and using, please read the manual carefully. The UPS must be installed and configured by an authorized service center of the manufacturer or distributor. In the case of installations by persons without the required experience, there is a risk of users being exposed to health or life. Persons not entitled to the installation may damage the power supply, which in this case is not subject to the terms of the warranty.



### **FULFILLED STANDARDS**

The device complies with the directives CE 73/23 and 93/68 (low voltage safety) as well as 89/336 (EMC) and the following standards:

\*IEC62040-1-1

\*IEC/EN62040-2 EMC CLASS C3

\*IEC62040-3



### **NOTE - Large leakage current**

The connection of the protective conductor (PE) is essential and must be made before connecting the remaining working conductors (power supply, consumer, battery).

Grounding should be carried out in accordance with prevailing standards and practical knowledge applicable at the place of installation. The leakage current exceeds 3.5 mA and is less than 1000 mA.

When choosing immediate-action RCCB or RCD devices, the transient and fixed leakage currents that may occur during commissioning must be taken into account.

Select residual current circuit breakers (RCCB) that are sensitive to unidirectional DC current pulses (Class A) and insensitive to transient current pulses. It should also be remembered that a given RCCB or RCD device conducts the leakage currents of the receiver.



### **Operation**

There is dangerous voltage in the uninterruptible power supply housing. The risk of contact with such a voltage is kept to a minimum, as live components are behind a closed housing. Additional internal protective covers make the device protected in accordance with IP20 protection class.

Normal operation of the device, taking into account the recommended operating procedures, poses no threat to personnel.

All maintenance and service procedures require access to the interior of the device and should only be carried out by trained employees.



### **High battery voltage > 400 Vdc**

All work related to the operation and installation of batteries can be performed by a properly trained service.

After connecting the battery, the voltage at their terminals exceeds 400 Vdc and is potentially lethal.

Battery manufacturers give detailed precautions that must be followed when working on or around battery-powered large batteries. Such measures should always be strictly observed.

Particular attention should be paid to recommendations regarding local environmental conditions and the provision of protective clothing, first aid and fire-fighting equipment.

## 2. Installation procedure

This chapter is devoted to the method of installation, method of laying and wiring of the UPS.

### 2.1 Introduction

The chapter presents the basic requirements for the location and wiring of the power supply. The description presents a step by step installation instruction, which is a series of guidelines for the service to be followed during assembly.



#### **Warning - Installation may only be carried out by an authorized service center**

1. Do not connect electrical equipment to the power supply before finding a service technician that the power supply is properly connected and configured.
2. The UPS should be installed by qualified technical personnel in accordance with the guidelines contained in this chapter.

Do not perform any electrical work interfering with the electrical installation before and after the UPS, during operation of the UPS system. Damages resulting from this title (eg change of phase sequence) are not covered by the guarantee.



#### **Warning: dangerous batteries**

Special precautions must be observed when working with batteries connected to the power supply. After connecting the battery, the voltage on the terminals exceeds 400 Vdc and is potentially fatal. To protect your eyes against accidental arcing, it is recommended to use safety goggles. Additionally, it is recommended to:

- Remove rings, watches and all metal objects.
- Only use tools with insulated handles.
- If electrolyte leaks from the battery or the battery is otherwise damaged, it must be replaced. Damaged batteries should be stored in a container resistant to sulfuric acid and disposed of in accordance with local regulations.
- If the electrolyte comes into contact with the skin, immediately contaminate the contaminated area with water.

### 2.2 Preliminary review

Perform the following checks before installing:

- Check visually that the supplied devices, i.e. the UPS and batteries, have not been damaged as a result of their transport. Damages should be reported immediately to the supplier.
- Verify compliance of the delivered equipment with the installation requirements. The power of the PSU is described on the label each time.

## **2.3 Location**

### **2.3.1 UPS Room**

The UPS is intended for indoor installation. The device should be in a clean environment with adequate ventilation to maintain the ambient temperature within the required specification range. The UPS provides forced convection cooling via internal fans. Cold air enters the device through ventilation openings located in the front part of the housing and is blown out by grills in the back of the housing. Do not block the ventilation openings.

Depending on the room conditions, the ventilation openings of the power supply should be regularly cleaned, eg with a vacuum cleaner. The ventilation will ensure efficient cooling and will extend the life of the device.

Note: The UPS should be installed on a stable and non-flammable substrate.

### **2.3.2 Battery room**

Battery temperature should be stable, as it is the main parameter affecting the battery life and capacity. The optimal battery temperature is 15-25 °C. It is recommended to maintain a nominal temperature of 20 °C. Working at a higher temperature will shorten the battery life, and at a lower temperature will reduce their capacity. Any increase in battery operating temperature by a further 8 °C, reduces the service life by 50%. Keep batteries away from heat sources and hot air outlets. When installing the battery outside the UPS, use the battery circuit protector located as close as possible to the battery. The cables connecting the batteries and the UPS should be as short as possible.

### **2.3.3 Storage**

If the device is not installed and requires storage, protect it from excessive moisture and high temperatures. Store batteries in a dry and cool room. The most suitable storage temperature for batteries is 20-25 °C. If the device has not been installed immediately after delivery, store it in a room to protect it from excessive moisture and heat sources.

## **2.4. Unpacking, checking and setting up**

Before unpacking, carefully inspect the delivered packaging of the device for damage during transport. After removing from the packaging, check that the equipment does not show signs of damage. If any damage occurs, please report it to the supplier immediately.



## 2.4.1 Unpacking

The power supply is delivered in a cardboard package on a wooden pallet. For unpacking, remove the carton and protective foams inside the package. The device shown below is shown after disassembling the packaging.

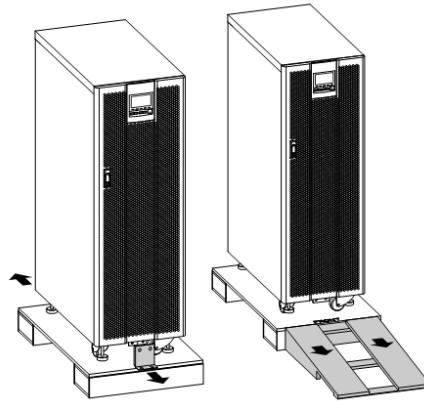

View of the sample power supply after disassembling the packaging

Note: Remove the screws that connect the UPS enclosure to the wooden pallet, then place the power supply at the point of installation using the exit provided in the UPS enclosure. Disassembly should be carried out carefully so as not to damage the housing.

The 60kVA power supply is equipped with brake wheels, and the 80kVA power supply has additional feet to stabilize the UPS after it has been positioned at its destination, as shown below.

Check the correctness of the delivered equipment on the label located on the back of the UPS door. The label contains basic information about the model, power, etc.

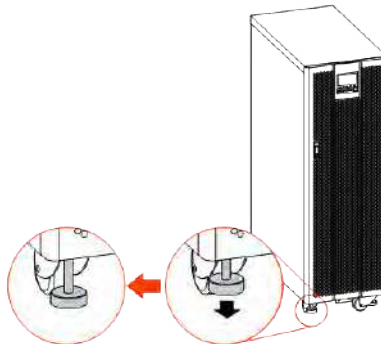

Note: Dispose of the safety materials (wood, plastic, etc.) after disassembly in accordance with the applicable local environmental regulations.

In order to extend the service life of the device, it is necessary to provide a suitable place for its installation, which should guarantee

- Protection against gases and vapors that may cause corrosion
- Easy connection to the electrical system
- Sufficient service space
- Protection against excessive moisture and heat source
- Suitable fire protection
- The working temperature should be in the range of 20-25°C. At this temperature, the batteries exhibit optimum performance.

### 2.4.2. Design and dimensions of the UPS

The appearance and dimensions [mm] of the UPS are shown in the figures below:

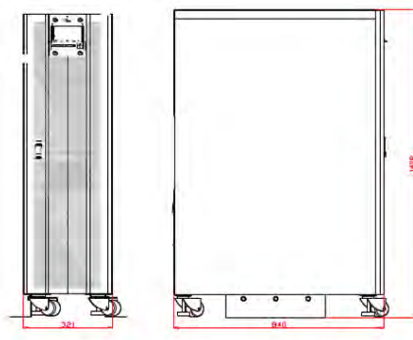

The front/side view of the MT 20K,30K UPS

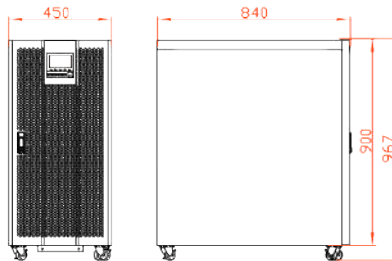

The front/side view of the MT 60K UPS

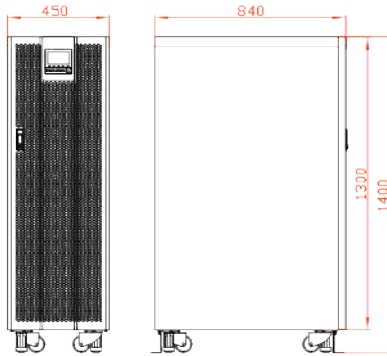

The front/side view of the MT 80-120K UPS

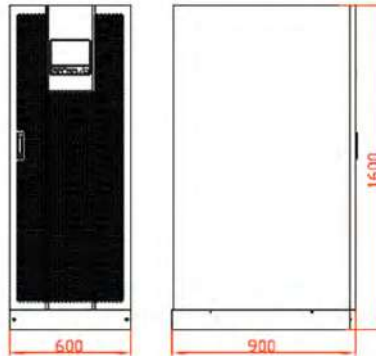

5 The front/side view of the MT 160-200K UPS

### 2.4.3. Service space

There are no ventilation openings on the side walls of the power supply, therefore no free space is required from the side for ventilation purposes. However, for access to the device from each side, it is recommended to keep min. 50 cm of service space.

It is required to provide adequate space from the front of the power supply for easy operation and the possibility of drawing cold air from the environment. Recommended space from the front 80 cm. Due to the required access to the back of the power supply and the free air blow and circulation, the recommended space from the back of the power supply is 50 cm.



## 2.5. Safety elements

For safety reasons, it is necessary to install appropriate protections in the form of circuit breakers or other protective devices in the UPS power supply switchboard. This chapter provides general practical information for the installation needs of qualified electricians. In addition, personnel with appropriate knowledge and qualifications should have knowledge about standards on the local market regarding the type and cross-sections of cables, their arrangement and loadability. It is recommended to use flexible LgY or OpD type hoses.

### 2.5.1. UPS input power supply

The UPS should be supplied from an electrical switchgear equipped with a suitable security device selected for the maximum system power, and flexible hoses with appropriate current carrying capacity matched to the protection used.

If it is required to install RCDs on the UPS, please note that these devices should:

- be sensitive to unidirectional DC current pulses (class A)
- not be sensitive to transient current pulses
- have adjustable sensitivity in the range of 0.3 - 1A.

The RCD must be sensitive to unidirectional DC current pulses, and insensitive to transient current pulses, as shown in the figure below:

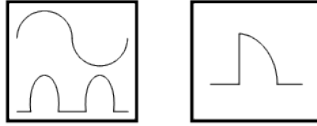

Marking the RCD

### 2.5.2. Battery circuit protection

The battery required for the correct operation of the power supply consists of 30 - 40 12 V batteries connected in series. A 3 wire installation is required with a neutral center point, taken from the central connection between the 20 and 21 batteries, in the case of a 40-battery chain. The battery circuit must be protected by a suitable fuse, selected according to the UPS power. A detailed drawing of the battery installation is shown below:

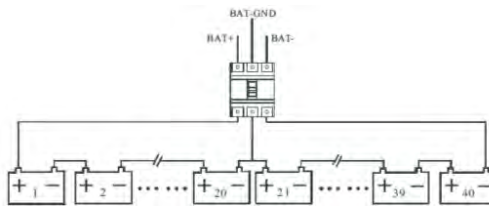

Diagram of connection in series 40pcs of battery with a central center point

### 2.6. Power cords

The main factors that influence the selection of wires are the supply voltage, the current, and the room temperature and cable installation conditions. The system power cords must be selected in accordance with applicable regulations at the place of installation and be consistent with the following description:

The input power supply cables must be matched to the maximum input current and the maximum battery charging current indicated in the table below, taking into account the power rating of the power supply and the AC input voltage. The output and bypass cables must be matched to the rated output current given in the table, taking into account the power rating of the power supply and the AC output voltage.

Battery cables must be matched to the discharge current of the battery at the voltage at the end of discharge, given in the table, taking into account the power rating of the PSU. The terminal strip for connecting the power / supply wires is located on the front of the power supply. On the strip, screw-eye connections are used. The cable connection is located on the bottom of the power supply shown in figure below:

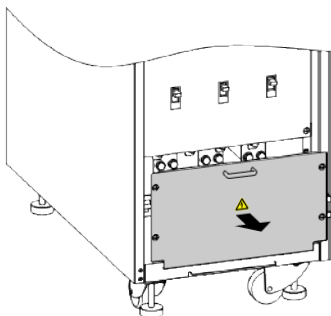

View of the front wall of the power supply and the place where the wires are connected

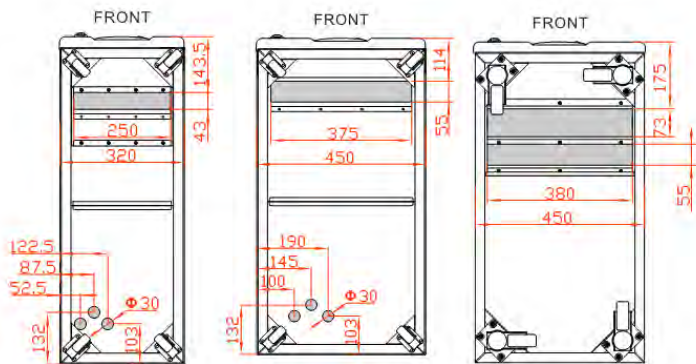

View of the bottom of the power supply and the MT 20K,30K (left), MT 60K (center) and MT 80-120K (right)

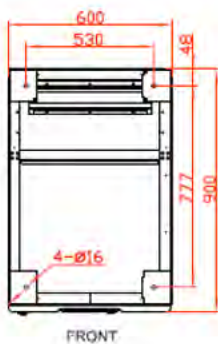

View of the bottom of the power supply for MT 160-200K.



### Attention

Before performing the wiring of the power supply, make sure that the position and function of external distributes will combine the input / output power supply with a power distribution panel. Check that the foregoing power sources are electrically disconnected and then insert your necessary key warnings to prevent their incident inclusion so that the voltage does not appear on the cables when the ups is powered.

## 2.6.1. Maximum power supply currents

The currents for the maximum system power given in the table below, depending on the power of the system. The given currents are used to select the appropriate protections in the power, battery and receiver lines as well as the appropriate cable cross-sections. Currents given at 230 / 400Vac installation.

System		MT20,30k	MT60k	MT80k	MT100k	MT120k	MT160k	MT200k
Power		20,30kVA	60kVA	80 kVA	100kVA	120kVA	160kVA	200kVA
Dimensions (mm) (WxDxH)		321x840x 1428	450 x 840 x 967	450 x 840 x 1400			600 x 900 x 1600	
Input	Nominal current [A]	52	103	132	180	193	258	360
Output	Nominal current [A]	43	87	116	145	174	232	290



### Warning

The power supply requires the connection of a PE protective conductor. Incorrect connection of the protective conductor may cause the EMI filters to malfunction and result in electric shock or fire.

## 2.6.2. Connecting wires



### Warning

The operations described in this chapter should be performed by a properly trained team of service technicians. The contracting authority is responsible for preparing the power supply and receiving installation for the power supply.

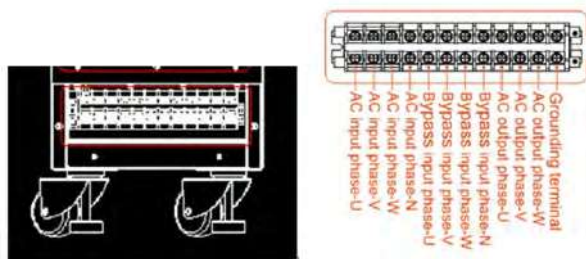

View of terminal block for connecting MT 20K,30K cables

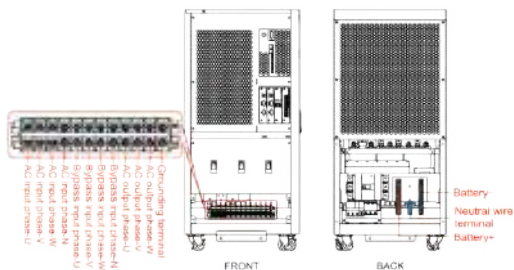

View of terminal block for connecting MT 60K cables

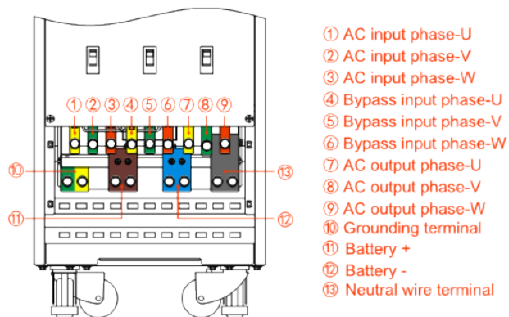

View of terminal block for connecting MT 80-120K cables



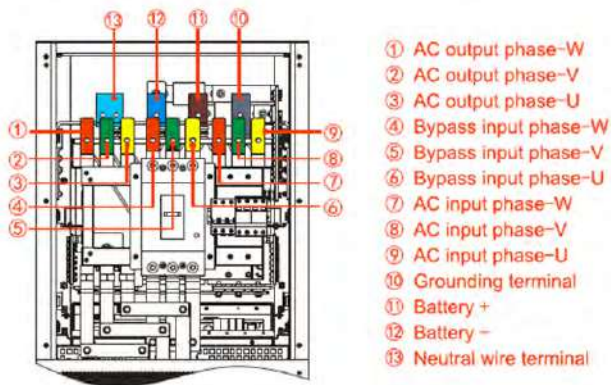

View of terminal block for connecting MT 160-200K cables

After properly setting and securing the power supply before moving it, connect the wires with the following rules:

1. Check that the power supply is completely disconnected from the external power source and that the service Bypass switch on the power supply is open. Ensure that these power sources are electrically isolated and arrange the necessary warning signs to prevent them from being accidentally switched on.
2. Open the front door of the power supply and remove the bezel to gain access to the place where the power cords are inserted. A terminal strip for connecting wires is located in the front of the power supply. Connecting the battery in the MZ 60K and MZ 80K UPS from the rear of the power supply.
3. Connect the protective ground wire. The connection must comply with local regulations and applicable standards.
4. Connect the UPS power supply (rectifier and bypass).
5. Connect the power cords between the UPS and the battery disconnecter. Check the correct polarity.



**Warning - Hazardous voltage at the battery terminals**

Make sure that the polarity of the battery is correctly connected. Positive terminal of battery to positive terminal (BAT +) on UPS, negative terminal of battery to negative terminal (BAT-) on UPS, neutral terminal of battery to neutral terminal (N) on UPS.

6. Install the protective cover and the power supply cover.

## 2.7. Communication

Communication interface of the MT 60K power supply is located behind the front door of the power supply, and consists of master control module (1), slave control module (2 - option), SNMP card (3 - option), extended relay card DryContact (4 - option), monitoring cards (5) and the UPS start button from the "Cold Start" battery (6).

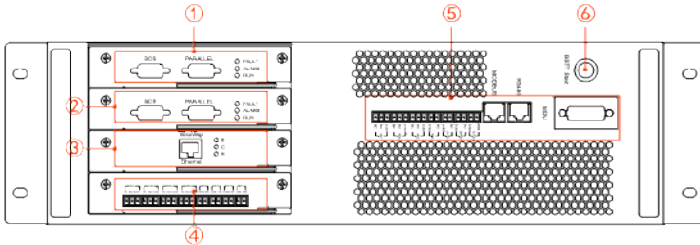

Communication interface of the MT 60K power supply

The communication interface of the MT 80-120K power supply is located behind the front door of the power supply, and consists of an extended DryContact relay card (1 - option), slave control module (2 - option), master control module (3), SNMP card (4 - option) and monitoring cards (5).

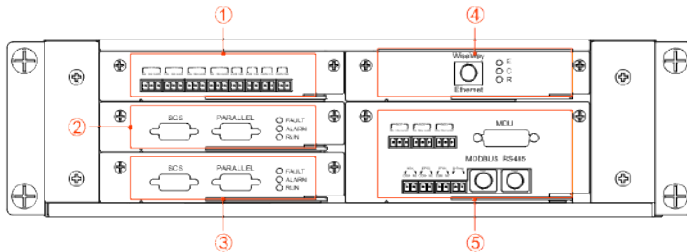

Communication interface of the MT 80-120K power supply

The communication interface of the MT160-200K power supply is located behind the front door of the power supply, and consists of an extended DryContact relay card (2 - option), slave control module (3 - option), master control module (4), SNMP card (1 - option), and monitoring cards (5).

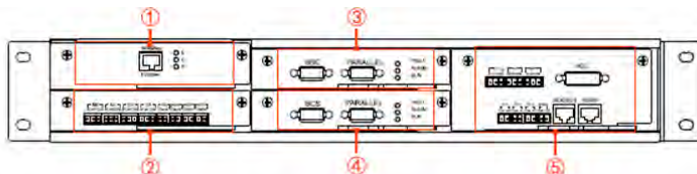

Communication interface of the MT 160-200K power supply

The cables connected to the DryContact interface must be potential-free and separated from the AC working conductors. Wires should be double insulated with a cross-section of 0.5 - 1.5 mm<sup>2</sup>, and their maximum length should not exceed 50m.

### 2.7.1. Extended communication card Dry Contact

The extended Dry Contact card allows you to connect seven additional signals, including four input signals and three output signals. The description of signals is presented in the table below:

Output Signals

No.	Description	Purpose	Description
1	ND5	The signals can be set as: triggering the battery switch in case of EPO activation, output signal informing about the position of the output disconnecter in the OFF position, bypass operation, synchronization signal, start or stop signal of the unit operation.	The occurrence of the event results in the closing of NO-COM pins and the opening of NC-COM pins. Permissible values of 1A / 250V signals.
2	ND6		
3	ND7		
4	ND8		

Input Signals

No.	Description	Purpose	Description
1	ND9	Input signals from external devices informing about the operation of the unit, power supply failure at the UPS input or grounding of the battery.	The occurrence of the event results in the closing of NO-COM
2	ND10		
3	ND11		
4	ND12	Reserve	The occurrence of the event results in the closing of NO-COM

### 2.7.2. Control module

The UPS is equipped as standard with a control module that manages the operation of the UPS, which is also used for parallel communication of the power supplies. An optional solution is a redundant control module card, acting as a redundant module, which is standard equipment in the case of a parallel system.

### 2.7.3. SNMP card

The SNMP card allows the user to remotely manage and read device operation parameters via the network. A detailed description of the possibility of the SNMP card contained in it in the instruction manual of the card.

### 2.7.4. Monitoring card

The monitoring card enables communication by means of Modbus and RS-485, additionally has 6 dry contact contacts (3 input ports and 4 output ports).

Output Signals

No.	Description	Signal	Function
1	ND1	UPS fail	The occurrence of the event results in the closing of NO-COM pins and the opening of NC-COM pins. Permissible values of 1A / 250V signals.
2	ND2	No supply	The occurrence of the event results in the closing of NO-COM pins and the opening of NC-COM pins. Permissible values of 1A / 250V signals.
3	ND3	Low battery voltage	The occurrence of the event results in the closing of NO-COM pins and the opening of NC-COM pins. Permissible values of 1A / 250V signals.

Input Signals

No.	Description	Signal	Function
1	EPO1	External NO signal from the emergency switch REPO	The occurrence of the event requires the closing of the NO-COM pins.
2	EPO2	External NC signal from the emergency switch REPO	The occurrence of the event requires the closing of the NC-COM pins.
3	ND4	External bypass service signal	The occurrence of the event requires the closing of the NO-COM pins.

### 3. UPS operation modes

This chapter describes the basic modes of the UPS's operation, battery management and protection.



**Warning: There are dangerous voltages - mains and batteries inside the power supply**

Inside the UPS, there are no components requiring user. Only the authorized service of the manufacturer has the option of opening the UPS enclosure.

#### 3.1. Introduction

The UPS guarantees the highest reliability of power for critical devices. The voltage parameters generated by the power supply are stable and free of fluctuations in both voltage and frequency, and completely independent of the voltage parameters in the professional network. Obtaining high quality parameters guarantees high frequency double processing with pulse width modulation (PWM), all controlled using digital signal processing (DSP) which ensures high reliability and convenience of use.

#### 3.2. Principle of operation

As shown in the figure below, the supply voltage from the professional network powers the UPS rectifier. The rectifier converts alternating voltage (AC) to DC voltage. The DC voltage supplies the inverter system, which converts the DC voltage into a stable alternating voltage (AC), which is completely independent of the input voltage. In the absence of mains voltage, the inverter system is supplied from the voltage accumulated in the batteries. In the case of maintenance work, or in the event of overloading, overheating or other events on the UPS, a back-up power supply line is used Bypass track.

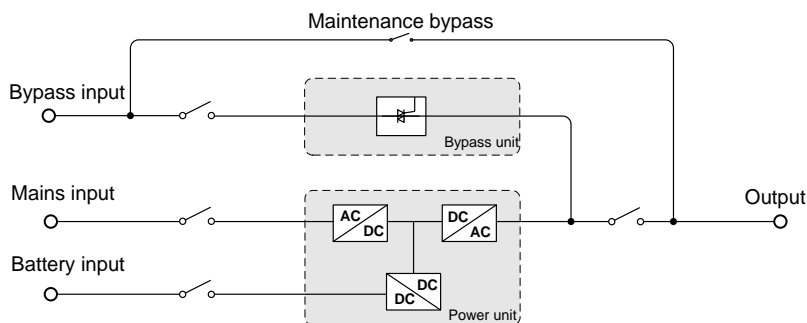

Block diagram of the power supply

### 3.2.1. Bypass module

The Bypass system is an electronic uninterruptible switch that supplies voltage to the receivers from the inverter output or via Bypass track. During normal operation, the receivers are supplied directly from the inverter output, but in the case of events such as overload, overheating or damage to the inverter, the loads are automatically switched to the power supply from the Bypass track. To ensure an uninterrupted switch between inverter operation and Bypass operation, the inverter output must be synchronized with the Bypass line voltage at all times. Synchronization is ensured by the inverter voltage and frequency control system, which guarantees synchronization of the frequency generated by the inverter to the Bypass voltage, provided that the voltage frequency in the Bypass remains within the permissible tolerance range. The UPS has been additionally equipped with a service Bypass system. Bypass is manually activated when maintenance work is required on the UPS. The Bypass service can only be enabled when the UPS is in the Bypass electronic mode.



#### Warning

When the UPS operates in Bypass or Bypass service mode, connected receivers are not protected by power failures and mains disturbances.

### 3.3. Power supply operation modes

MT series power supply is a device with double energy conversion, which allows you to work in the following modes depending on the configuration:

- Online mode
- Battery mode
- The restart mode of the power supply after power back
- Bypass mode
- Service bypass mode
- ECO mode
- Frequency converter mode
- Parallel mode

#### 3.3.1. Online mode

In normal operation, the output voltage from the UPS is generated by the inverter. Normal operation means that there is a voltage in the professional network with the appropriate parameters that powers the UPS rectifier. The rectified voltage is the power source for the inverter circuit, which produces a guaranteed voltage with stable parameters that are completely independent of the input voltage. In normal mode, battery packs are also charged.

### 3.3.2. Battery mode

In the event of a power failure in the professional network, the inverter of the power supply draws energy accumulated in the battery bank. During a power outage in the network, the switch to battery operation takes place in an uninterrupted mode, which means that no interruption in power supply is visible from the point of view of the powered receivers. The return of voltage in the professional network causes automatic return to work in normal mode, without the need for intervention.

Note: The UPS can also be started from the battery in so-called "Cold start", i.e. in the absence of a basic power supply.

### 3.3.3. The restart mode of the power supply after power back

In case of prolonged power failure, when the batteries are discharged after reaching the minimum voltage (EOD - End Of Discharge). The UPS inverter is turned off. The power supply unit can be configured to automatically restart after the time delay set by the service technician, after the power supply has been restored. The restart mode and any delay of switching on the inverter can be programmed by the manufacturer's service. During the programmed delay time of switching on the inverter, the batteries are charged so that after switching on the inverter, the receivers are protected in the event of a power failure.

### 3.3.4. Bypass mode

In the event of overloading the power supply, overheating or other reasons, eg damage to the inverter in the normal operation mode, the automatic supply of Bypass. Bypass is automatically and uninterrupted.

### 3.3.5. Service bypass

Manual service bypass in which the UPS has been equipped, enables periodic maintenance works on the device, without depriving the connected receivers of the power supply. The service Bypass can only be enabled when the UPS is in the Bypass electronic mode. Therefore, first of all switch the UPS to Bypass mode, and then turn on the service Bypass switch.



#### **Warning**

When the UPS is in Bypass service mode, power modules and LCD display do not work. It should be remembered that there is dangerous voltage on the terminal block to which the power supply and the load are connected.

### 3.3.6. ECO mode

In the ECO operating mode, the receivers are supplied directly from the network via the Bypass reserve track, which increases the efficiency of the power supply and reduces energy consumption. In the ECO mode, the preferred power source is the Bypass path until the voltage and frequency remain within the permissible tolerance. If the voltage parameters in the Bypass path are outside the specified tolerance range, the inverter output automatically switches to power supply. Switching depending on the network frequency is shorter than 15 ms for 50 Hz networks, and 12.5 ms for 60 Hz networks.

### 3.3.7. Frequency converter mode

In the frequency converter mode, the power supply can be used to generate a fixed value of an output frequency of 50 or 60 Hz. The range of input frequency tolerance at which a stable output frequency can be generated is 40-70 Hz. Bypass is not available in this operating mode. In the event of a power failure, the UPS generates the set frequency value using the battery voltage.

### 3.3.8. Parallel mode

MT series power supplies can work in parallel with each other to increase system power, or provide redundancy. MT series power supplies can operate in parallel to 8 devices, which means that the maximum power of the MT80K UPS system is 640kVA. In the parallel operation of the power supplies, the load is divided evenly between all working UPS units. In the case of a redundant system, eg N + 1, failure of a single unit does not affect the operation of other devices, and the system guarantees continuity of guaranteed power for the full power of the designed system.

## 4. User manual

This chapter contains detailed instructions on how to turn the power supply on and off, as well as switching between the modes described in the previous chapters. All control keys and the LCD panel used to switch between the modes described below are described in detail in Chapter 5. The acoustic signaling may appear during the following procedures.

### 4.1. Power connectors

The UPS can be switched on or off from the power supply by means of connectors mounted inside the power supply and accessible after opening the front door (60-80K) or rear side of UPS (20K,30K). The power supply's appearance is shown below, which is equipped with 4 connectors - Power breaker, Bypass breaker, output breaker, and a Maintenance bypass breaker at the back of the housing.

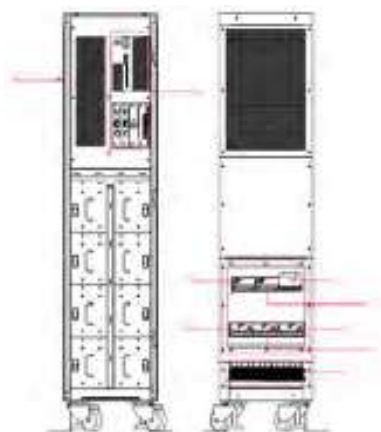

- 1 - Top cover plate
- 2 - Control unit
- 3 - Power breaker
- 4 - Bypass breaker

- 5 - Output breaker
- 6 - Battery breaker
- 7 - Maintenance bypass
- 8 - Wiring terminals



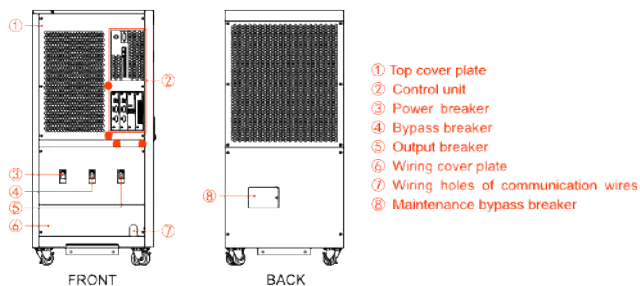

Locating power switches in the MT 60K power supply

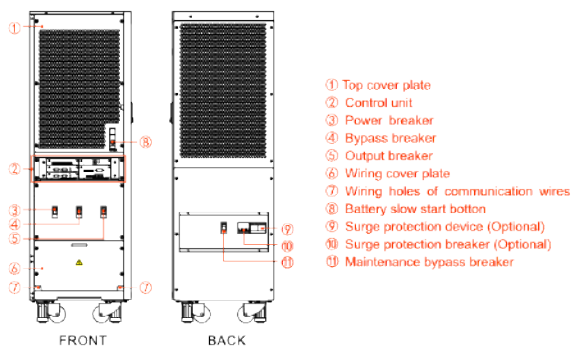

Locating power switches in the MT 80-120K power supply

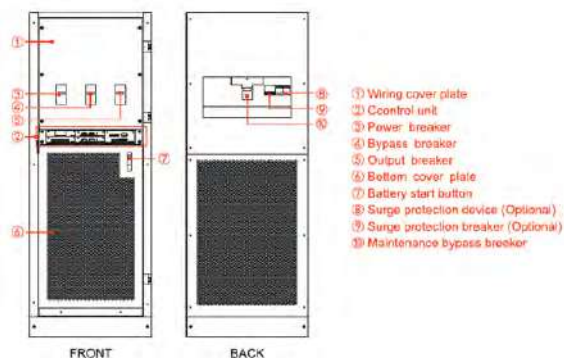

Locating power switches in the MT 160-200K power supply

## 4.2. Procedures for starting the power supply - single operation

### 4.2.1. Starting the UPS from complete shutdown

The following procedure should be used when starting up the power supply from the total off state.



#### Warning

When performing the following procedure, voltage appears at the output terminals of the power supply. If the receivers are connected to the power supply output, check whether the power supply is safe. If the receivers are not ready for power connection, make sure that they are safely isolated from the UPS output.

1. Close the bypass power switch (Bypass breaker).

After a while, the LCD display initializes and the UPS starts up to the bypass mode. The bypass diode should be green.

2. Close the power breaker.

Starting the inverter can be done in two ways, from the level of On keys on the display panel, or using commands from the display panel.

To start the UPS with the ON keys, press and hold both ON keys for three seconds simultaneously. The UPS will start the inverter.

To start the UPS with the help of the LCD touch screen, select the icon . The display switches to the on / off page. If the inverter was switched off, confirm switching on the inverter with the OK key.

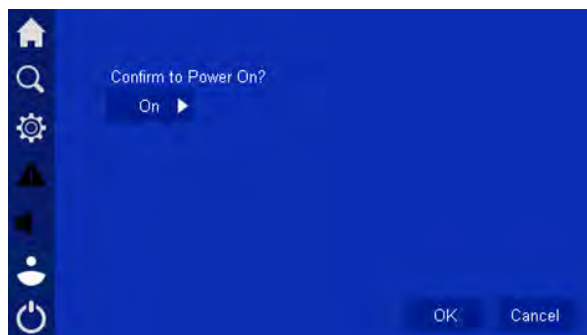

After starting the inverter, the bypass alarm is switched off.

3. Close the battery breaker located near the battery

4. Close the UPS output breaker.

The guaranteed voltage is applied to the receivers.

## 4.2.2. Starting UPS with the battery pack

1. Check if the batteries are connected. Close the battery breaker located near external batteries.
2. Press the "cold start" button on the power supply located on the front panel of the power supply.
3. The inverter starts automatically, the inverter diode flashes. The output of the power supply is switched on after approx. 60 seconds

The power supply operates in battery mode. The rectifier diode flashes red.

## 4.3. Procedures for switching the power supply between operating modes

### 4.3.1. Switching from normal operation to battery operation

Open the rectifier's power disconnecter to disconnect the UPS. The UPS will go into battery mode. If the power supply should be switched back to normal operation, wait a few seconds and then close the rectifier's power disconnecter. After about 10 seconds, the rectifier is started and the normal mode is entered.

### 4.3.2. Switching from normal operation to Bypass operation

Press the key with the icon  on the LCD panel, and then confirm by pressing OK.



### Warning

Before performing the wiring of the power supply, make sure that the position and function of external distributes will combine the input / output power supply with a power distribution panel. Check that the foregoing power sources are electrically disconnected and then insert your necessary key warnings to prevent their incident inclusion so that the voltage does not appear on the cables when the ups is powered.

### 4.3.3. Switching from Bypass mode to normal operation

Press the key with the icon  on the LCD panel, then confirm switching on the inverter with the OK key. The UPS will switch from Bypass mode to the normal operation mode (On-Line).

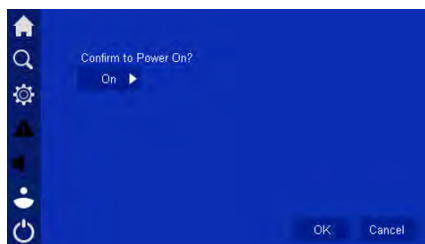

#### 4.3.4. Switching from normal operation to service Bypass mode

The procedures described below allow you to switch the UPS from normal operation to service bypass mode (Bypass service mode).



#### Warning

Before performing the following procedure, make sure that the voltage and frequency parameters in the Bypass path are correct and that the inverter is synchronized to the Bypass voltage. The fulfillment of these conditions guarantees an uninterrupted changeover of loads to bypass power.

1. Switch UPS to Bypass mode according to the instructions in chapter 4.3.2. The UPS works in Bypass mode, the UPS inverter is turned off.
2. Remove the bypass switch (Maintenance bypass breaker) cover located on the back of the power supply and switch the disconnect to the Bypass position. The loads will be powered by a bypass path. Open the rectifier and Bypass power disconnect switch disconnectors as well as the output and battery disconnect located outside the UPS.



#### Warning

If it is necessary to open the UPS housing, eg during maintenance work, wait a minimum of 10 minutes until the DC capacitors are discharged inside the module.

#### 4.3.5. Switching from service Bypass mode to normal operation

The procedure described below allows you to switch the UPS from bypass mode (Service Bypass) to normal operation.

1. Close the Output breaker and Bypass input bypass (bypass breaker). The Bypass LED will turn green.
2. Switch Maintenance bypass breaker to UPS position.
3. Replace the retaining plate by the Maintenance bypass breaker before accidental use.
4. Turn on the Power Breaker.  
After approximately 30 seconds, the inverter must be started according to the procedure described in 4.3.3
5. Close the battery breaker located in or outside the UPS. The battery diode will go off.

#### 4.4. The procedure of complete switching off the power supply (power supply by mechanical bypass).

To completely turn off the UPS and powered receivers, perform the 4.3.4 procedure to switch to Bypass service mode and then disconnect the power supply from the UPS in the power switchboard.

#### 4.5. Emergency shutdown using EPO

UPS emergency off button is located on the front panel of the UPS and is used for emergency shutdown in the event of flooding, fire, etc. Using the EPO switch causes immediate switching off the rectifier, inverter and disconnecting the voltage at the UPS output and stops the process of charging or discharging the battery.

In order to start the power supply for normal operation after using EPO, it is necessary to restore the emergency switch state to the normal position, give the supply voltage to the UPS and carry out the procedure of starting the power supply from the total shutdown. To do this, restore the switch position to the OFF position and follow the connection procedure in section 4.2.1.

### 5. LCD panel operation

The following chapter describes the functions and capabilities of the operator panel in the power supply, including key functions and available information from the level of the LCD touch screen.





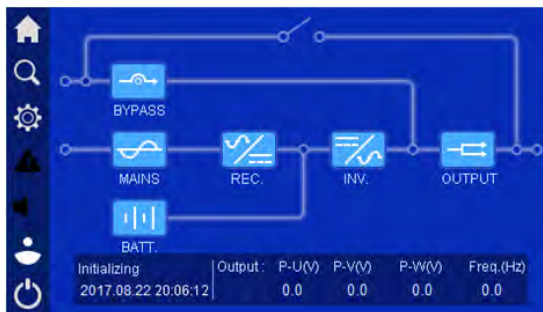









#### 5.1. Introduction

The UPS control panel with the LCD display is located on the front panel of the UPS. The LCD display provides the user with full access to the control of the operating status, switching between operating modes as well as the control of work parameters and event recording. The following is the appearance of the home page of the display and the meaning of individual icons that may appear on it.



Touch display

Description of symbols used on the power supply's operation panel

Symbol	Function
	Power supply bypass. In case of incorrect power supply parameters, the icon flickers and lights up  .
	Power supply rectifier. In case of incorrect power supply parameters, the icon flickers and lights up  .
	Battery status. In case of incorrect voltage or its absence, the icon flickers and lights up  .
	Output system. In case of incorrect voltage or its absence, the icon flickers and lights up  .
	Back to main page.
	Event history.
	System parameter settings.
	Warnings.
	Speaker.
	Log out.
	Turn on/off.

## 5.2. Indication of UPS operation status on the display

The LCD display indicates all operating modes in which the UPS can work, such as: start, shutdown, parallel system output, mechanical bypass operation, bypass operation, battery operation, normal operation, aging mode, ECO mode, frequency converter mode, protection against error. The way of displaying in particular modes of operation is presented in the following pictures.

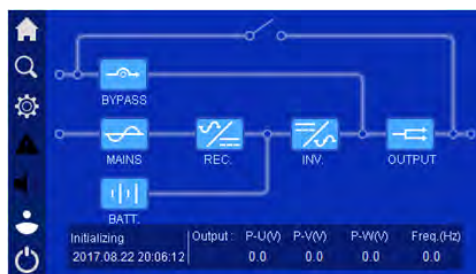

Starting (initialization)

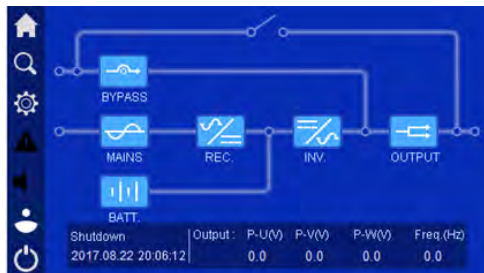

Shutdown

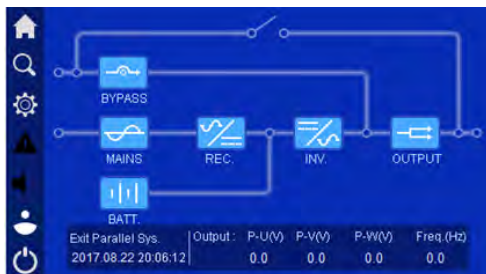

Exit from the parallel system

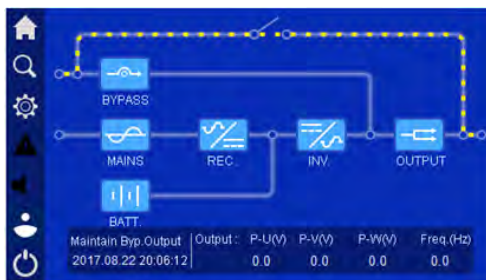

Work on the bypass service

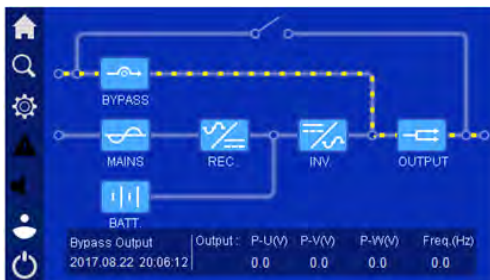

Bypass mode

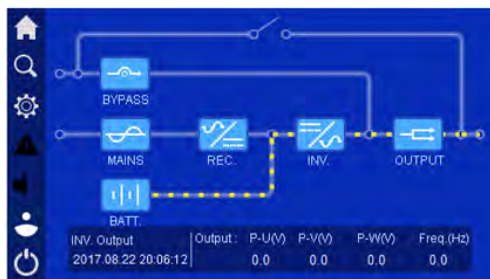

Battery mode

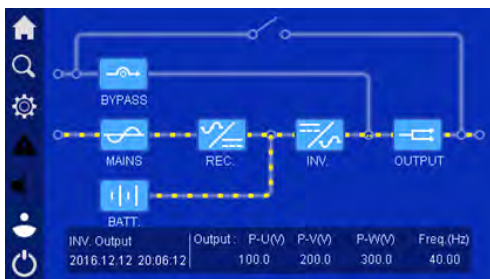

Online mode

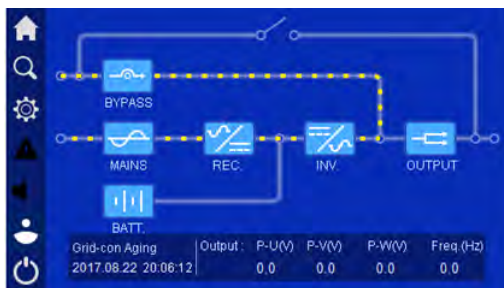

Aging mode

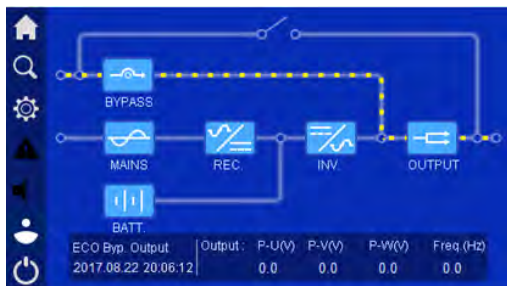

ECO mode



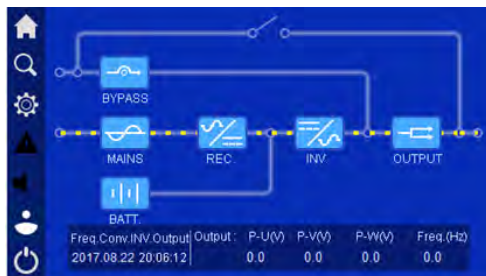

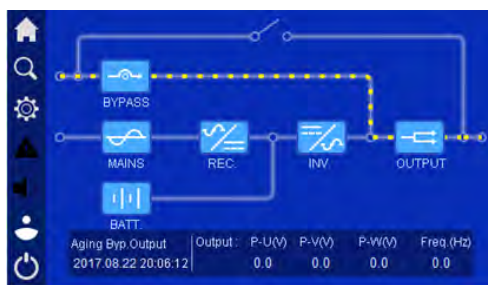

Frequency converter mode

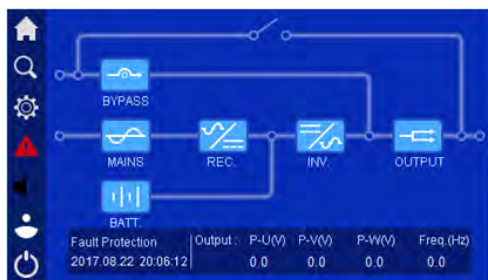

Aging bypass output mode



Fault protection

When an abnormal power supply is detected, an exclamation mark icon  on the left side of the menu is highlighted. Clicking the icon allows you to view the current alarm states with the exact date and time of the occurrence of the event, as shown below.

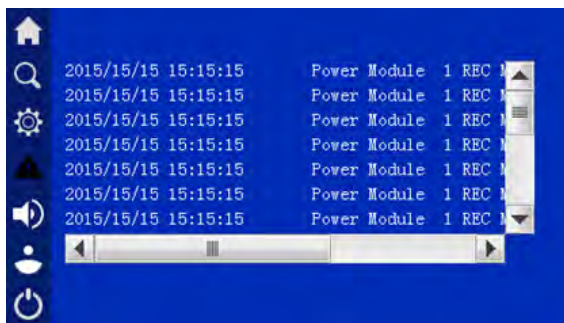

Window recorded error/failure

### 5.3. Reading work parameters

#### 5.3.1. Power supply to bypass track

Clicking the icon  on the main page of the display, it allows you to go to the preview of power supply parameters of the bypass. Available parameters are described in the display picture below:

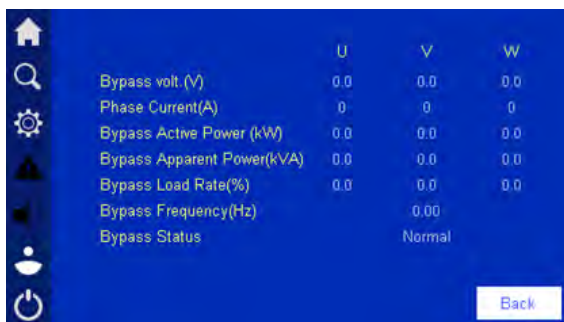

Information on the bypass power supply

#### 5.3.2. Power supply to the rectifier's track

Clicking the icon  on the main page of the display, it allows you to go to the preview of power supply parameters of the bypass. Available parameters are described in the display picture below:

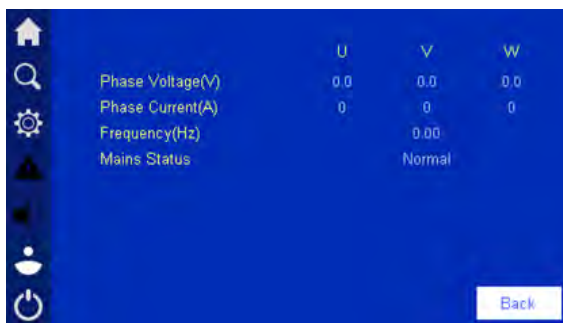

Information about powering the rectifier track

### 5.3.3. Battery

Clicking the icon  on the main page of the display, allows you to go to the preview of battery parameters. Available parameters are described in the display picture below:

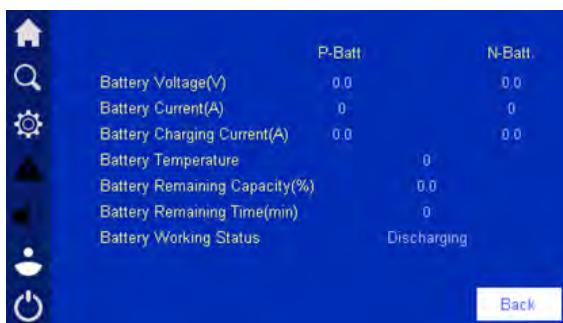

Information about battery parameters

### 5.3.4. UPS output

Clicking the icon  on the main page of the display, it allows you to go to the preview of the output parameters of the power supply. Available parameters are described in the display picture below:

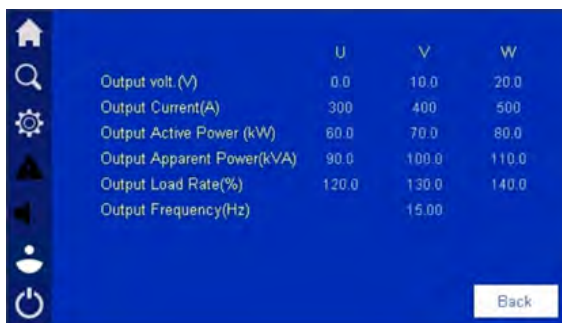

	U	V	W
Output volt.(V)	0.0	10.0	20.0
Output Current(A)	300	400	500
Output Active Power (kW)	60.0	70.0	80.0
Output Apparent Power(kVA)	90.0	100.0	110.0
Output Load Rate(%)	120.0	130.0	140.0
Output Frequency(Hz)		15.00	

Information on the UPS output parameters

## 5.4. Reading information about UPS (Event log)

Clicking the icon  on the home page of the display, allows you to go to the page with the history of events and information about UPS.

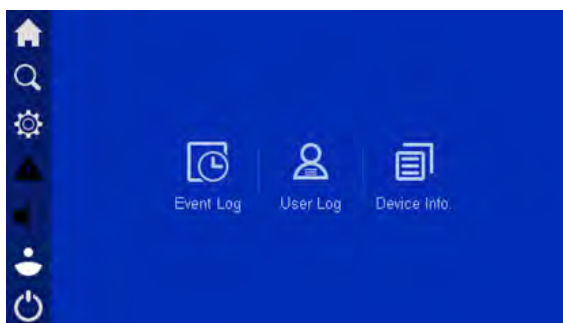

Information page

**Warning!** The memory allows you to store 10,000 registered events. If the number of events exceeds this value, the next event will be overwritten. All records are filtered according to the date and time of creation.

### 5.4.1. Event Log

Clicking the icon  on the information page, allows you to go to the page with the UPS event history. The page contains all recent events and alarms that have been registered by the system.

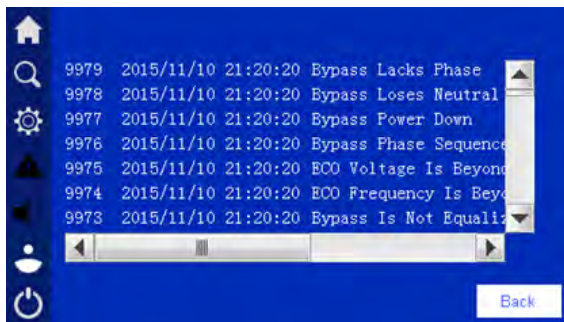

Event Log

### 5.4.2. User Log

Clicking the icon  on the information page, allows you to go to the page with the history of UPS startups and user activities.

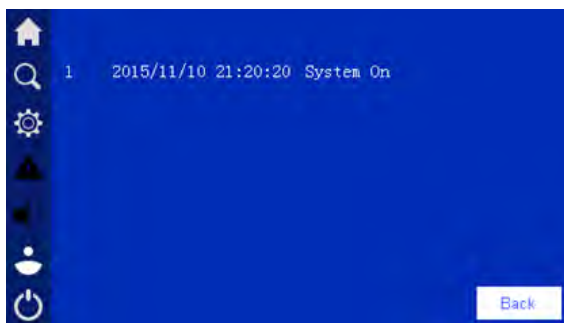

User Log

### 5.4.3. Information about the device

Clicking the icon  on the information page, it allows you to go to the UPS information page.

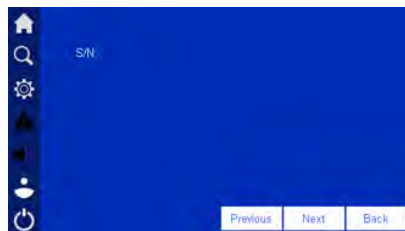
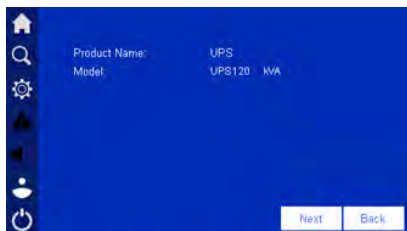

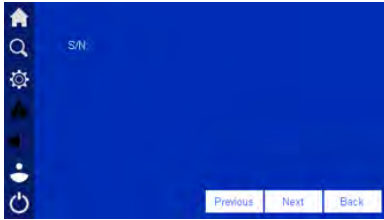

Information about UPS

### 5.5. System configuration settings

Clicking the icon  on the main page of the display, it allows you to go to the configuration page of parameters and modes of the UPS operation. To enter the configuration page, log in to the system by entering the user password.

The ordinary user, after entering the password 111, has access to the parameters of the UPS, but can not change them. Only the user with the service password has access to changing the system operation parameters.

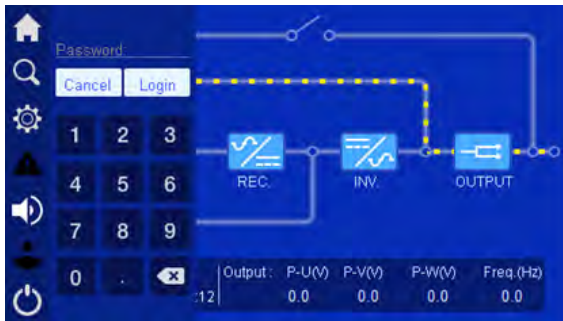

Log in

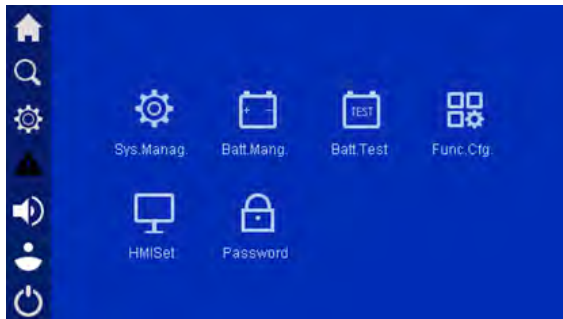

UPS settings page

### 5.5.1. Power parameters

Clicking the icon  on the settings page, it allows you to go to the configuration page of UPS parameters and modes.



Power supply parameters of the rectifier, bypass and ECO mode settings

### 5.5.2. Battery settings

Clicking the icon  on the settings page, allows you to go to the battery parameters configuration page.



Battery parameters

### 5.5.3. Battery tests

Clicking the icon  on the settings page, allows you to go to the battery test page. The standard test allows you to conduct a short battery test, a deep battery test allows them to discharge to a low battery voltage.

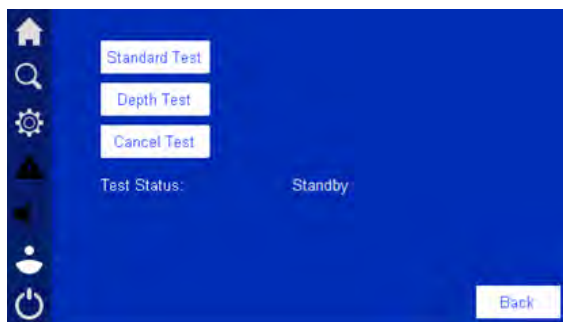

Battery tests



## 5.6. Special functions

Clicking the icon  on the settings page, it allows you to go to the settings page related to the operation of the unit and set the "UPS ventilation" function in order to dedust it.

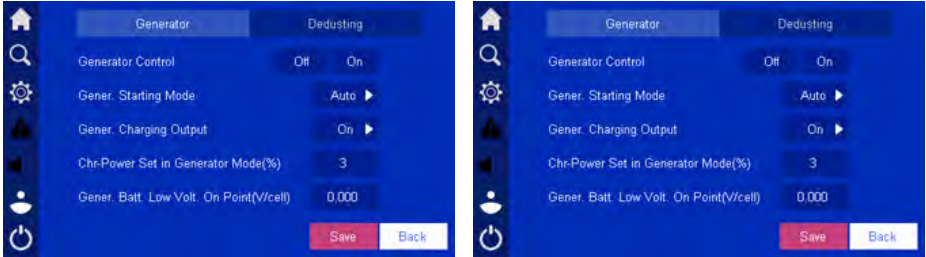

Special funtions

## 5.7. Display settings

Clicking the icon  on the settings page, allows you to go to the settings page related to the current system date, language and contrast.



Display settings

## 5.8. Password settings

Clicking the icon  on the settings page, allows you to go to the page with the option to set a new password.

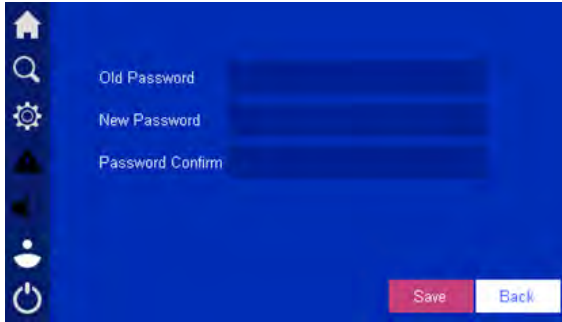

Password settings

## 5.9. System speaker

When an alarm situation occurs, the system informs you about the event with an audible signal. The user can always mute or activate the alarm by clicking on the icon . After silencing the alarm, the arrival of a new one will cause the signaling to be restarted.

## 5.10. Turn On/Off

Clicking the icon , goes to the page Enable / Disable the UPS inverter. Depending on the current operating mode (inverter on or off), you will go to the page as in the picture below. To confirm the operation, press OK.

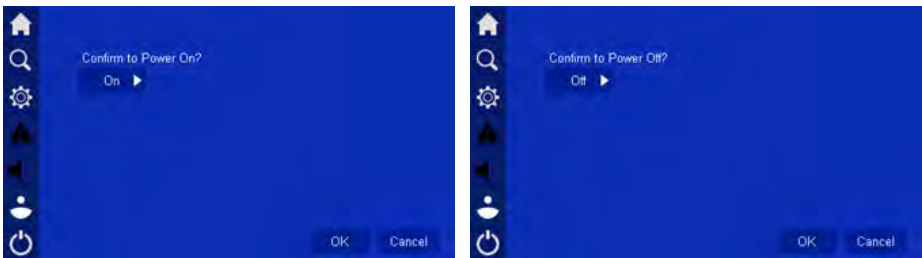

On/Off page of the inverter



 **ModSecur**<sup>®</sup> **UPS**  
*Uninterruptible Power Supply*